DOOR MANUAL
PL100 PANIC HANDLE
PL100-F SERIES

For all glass doors

Content of this manual:

DOOR FABRICATION (panic handle installation) - page 3

Parts list, tools & supplies required

Installation of handle to door

Actuator post alignment & nylon bushing selection

DOOR INSTALLATION - page 9

Door stop with manual strike

Header preparation for adjustable door stop with *manual strike*

Installation of panic strike & panic handle adjustment

Bolt adjustment for proper engaging with the strike

OPTIONAL—DOOR STOP WITH ELECTRIC STRIKE

Header preparation for adjustable door stop with *electric strike*

Installation & adjustment of door stop—strike

HANDLE CARE & MAINTENANCE

Care & cleaning

Stainless steel polished & brushed finish

Brass/bronze mirror polished & brushed (satin) finish

Oil rubbed bronze

Routine maintenance

Repair & replacement (replacing lock cylinder)



Parts list

- Enclosed are the following parts:
- Flat head socket screw
- Actuator post with cylinder operating pin & handle return pin with spring
- Nylon bushing
- Cylinder housing
- Adapter block with installation screws
- Threaded pin
- Exterior handle installation screw
- Exterior cap

Tools & supplies needed

- A set of allen wrenches
- A set of nylon bushings
- One 10 inch non marring channel lock pliers (optional)
- One spanner wrench

To begin installation, your door lite must be laid on a pair of saw horses with the exterior side of the door facing downward and the interior (panic side) facing upward.

Any and all applicable rails should be previously set, making sure to position the interior panic mounting hole in the rail towards the leading edge or strike side of the door.



Important information

Apply thread locker / Loctite
to all fasteners used on handles
interior & exterior

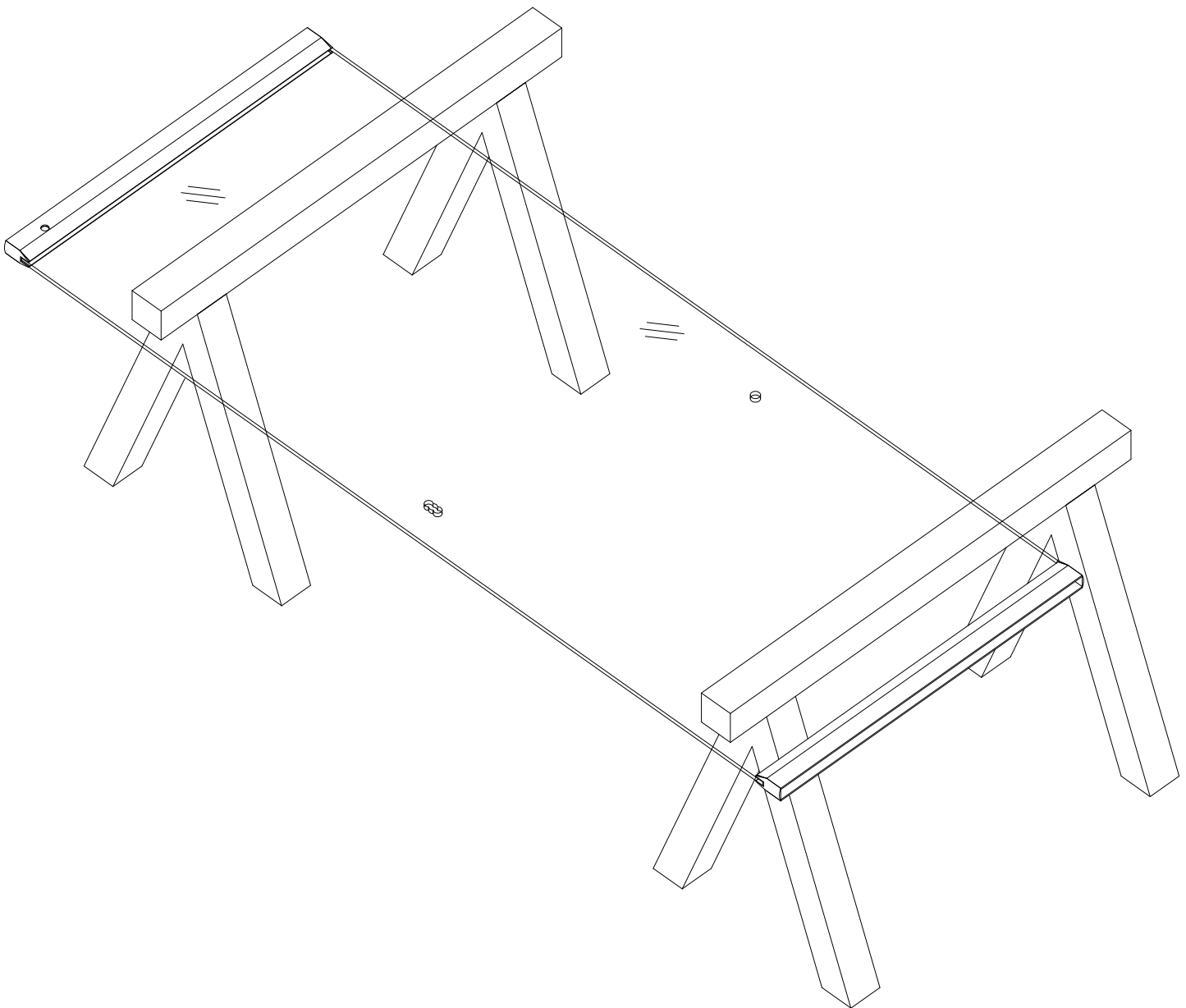

Rail mount handle application

(A) Install adapter block inside the top rail using the two pre-drilled holes. Block is adjustable to align with the threaded pivot connector bracket hole on the rail

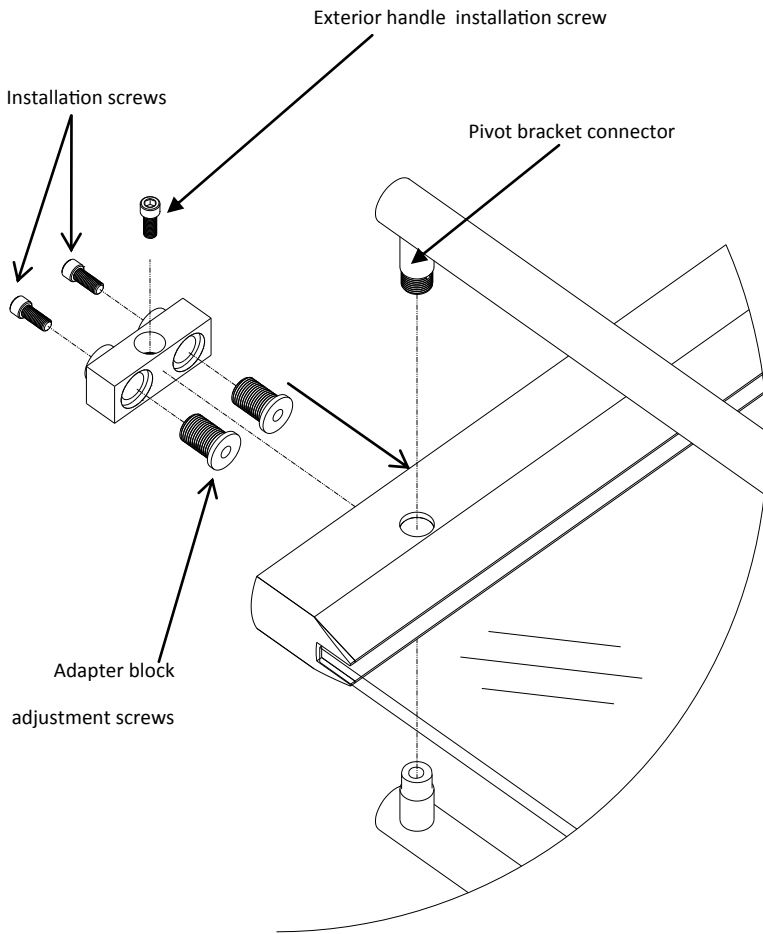

Rail mount "A"

Glass mount handle application

(B) Insert rubber bushing hole at top of glass door. Position exterior pivot bracket against exterior side into top notch. Align interior handle with exterior pivot bracket connector and tighten flat head socket screw

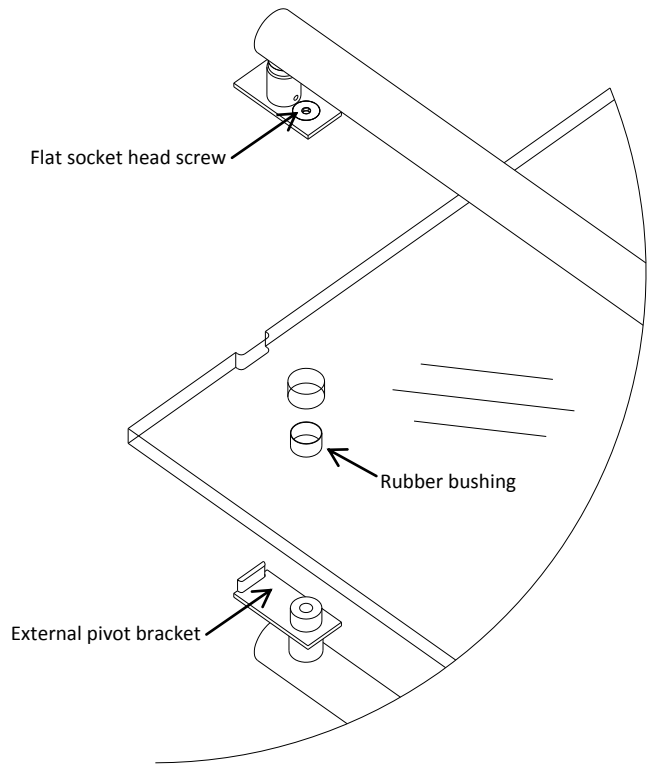

Glass mount "B"

INSTALLING THE HANDLE

1.- Insert the exterior cap retainer with the rubber bushing through the interior side into the exterior cap. Hand tighten.

Cap can be now tighten with pliers.

Care must be taken to prevent mar-ring by using a rubber strip

2.- With adaptor block in place (see page 4) raise exterior handle against face of glass & tighten exterior installation screws with allen wrench

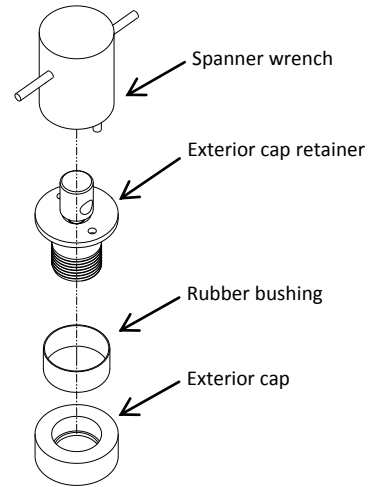
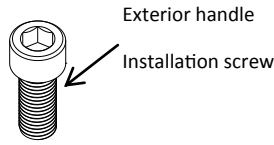

Important information

Apply thread locker / Loctite
 to all fasteners used on handles
 interior & exterior

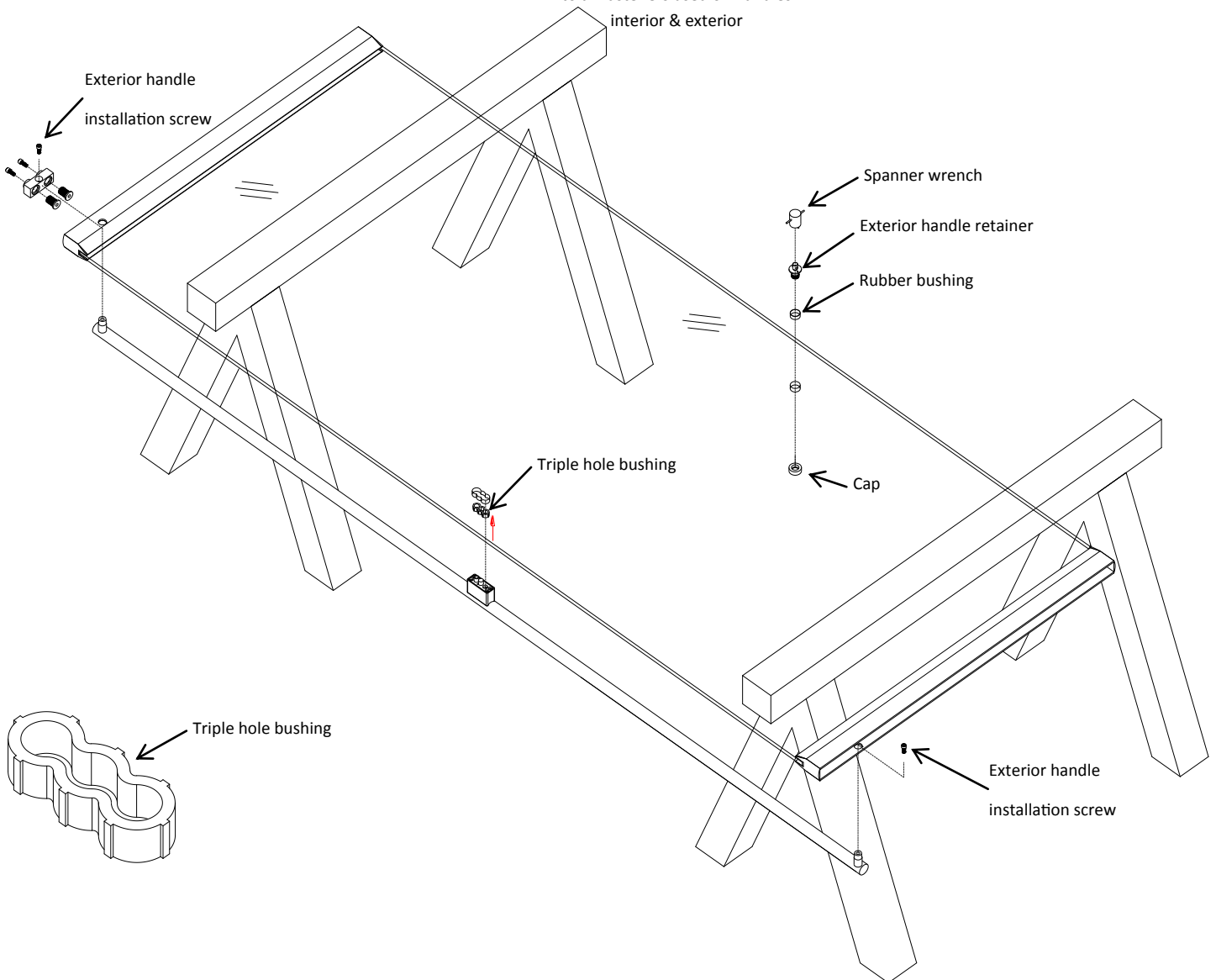

3.- Position the interior panic handle over the pivoting end of the exterior cap retainer. Make sure to align the hole on the pivoting projection. Insert the threaded pin and tighten with an allen wrench

Please refer to **actuator post alignment** and **bushing configuration** on page 7 & 8

This is a very important procedure.

(only one bushing to be used)

4.- Insert bushing into triple hole

5.- Lift the handle and insert actuator post containing cylinder operating pin, return spring and return plunger into handle. Place actuator base against glass over the triple hole bushing. Insert the cylinder housing or retainer plate into bushing

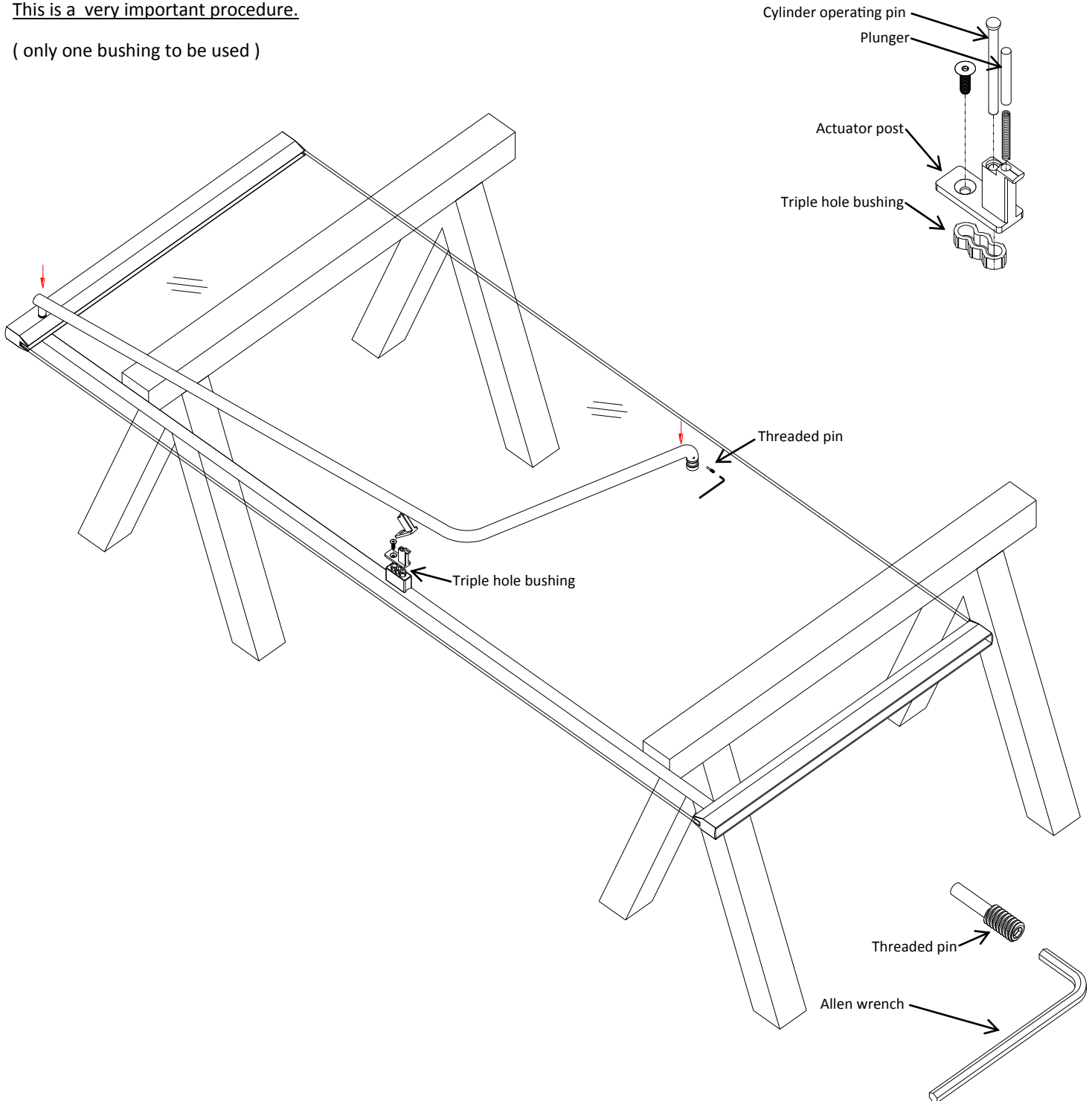

CRITICAL PROCEDURE

Before proceeding to the actuator post installation, it is now critical to verify the triple hole clamping alignment and assess which nylon bushing should be used. This hole alignment is important and to correct any misalignment holes, there are (4) different bushing inserts to choose from.

See below examples to help with your bushing selection to match what best suits your door.

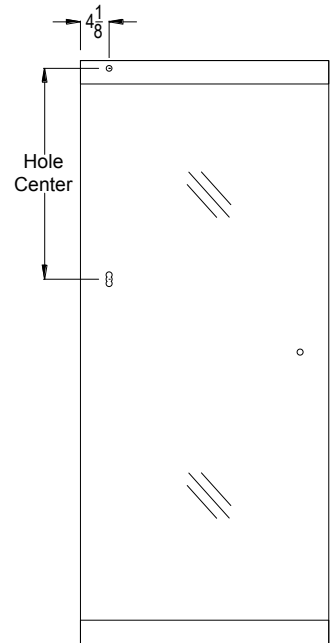

NYLON BUSHING SELECTION

Bushing "A" can be used if all holes at the top and center triple holes cutout line up perfectly.

Bushing "B" can be used if the triple hole cutout is 1/16" off from left to right from edge of door 4-1/8" required

Bushing "C" can be used when the height location of the triple hole cut out is off 1/16" however the edge 4-1/8" is correct

Bushing "D" can be used if both hole locations are off by 1/16 4-1/8 from edge of door & vertical hole center

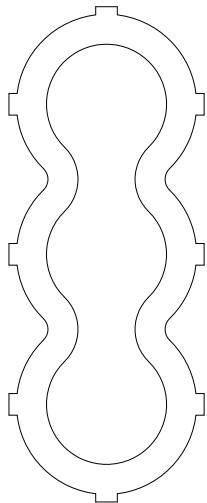

A

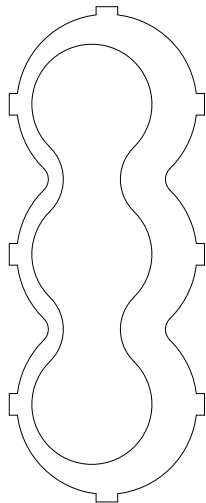

B

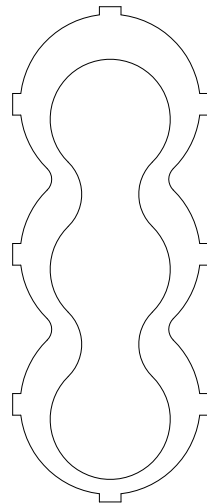

C

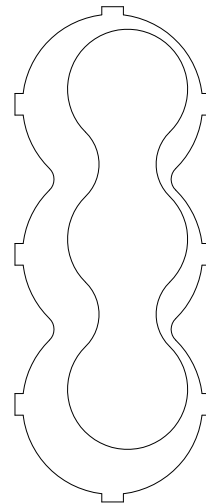

D

CRITICAL PROCEDURE

ACTUATOR POST ALIGNMENT

View from outside

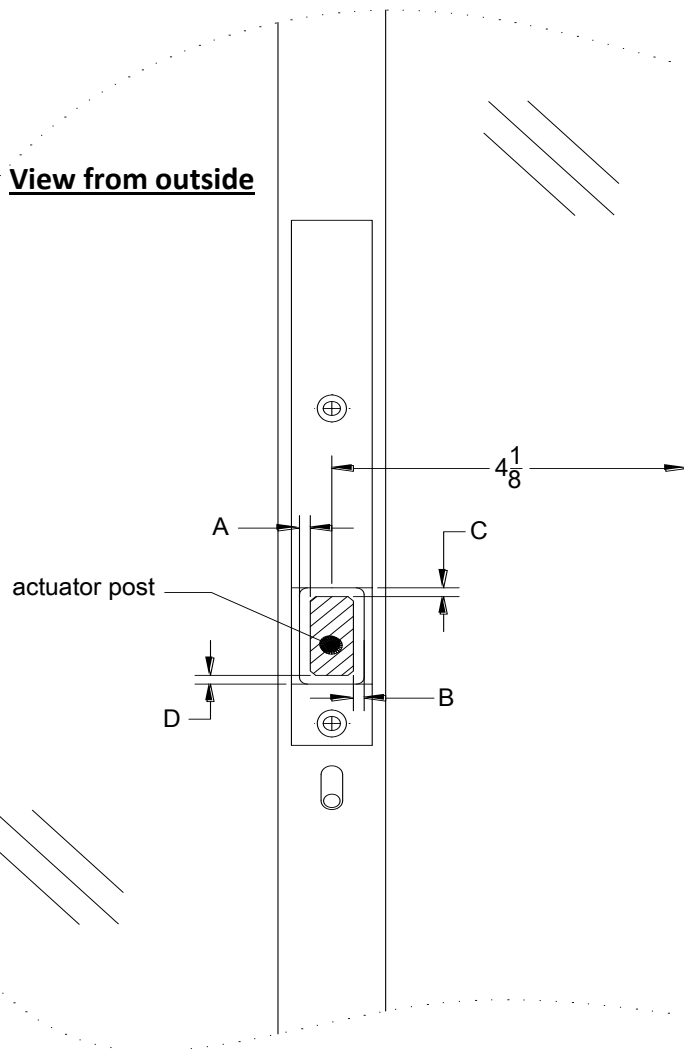

The actuator post must be centered within the rectangular slot in the handle

Location of the actuator post can be viewed through the glass to determine alignment .

When the handle is un-dogged & panic is at operational status, dimension "A" should be smaller than dimension "B"

while dimensions "C" & "D" will be equal.

When the handle is dogged in the unlocked position, dimension "A" should be larger than dimension "B"

and dimensions "C" & "D" should remain equal

DOOR INSTALLATION

To properly install the door you will find single or double adjustable door stops with screws & keys, which are supplied with the panic door installer manual.

Make sure you have

1ea 1/8" allen wrench

1ea 1/4" allen wrench

1ea thread locker / Loctite

PARTS LIST

Single or double adjustable door stops with required installation screws.

Keys, supplied with panic door installer manual.

HEADER PREP FOR DOUBLE OR SINGLE ADJUSTABLE DOOR STOPS WITH MANUAL STRIKE

MPS2 / DOUBLE DOOR

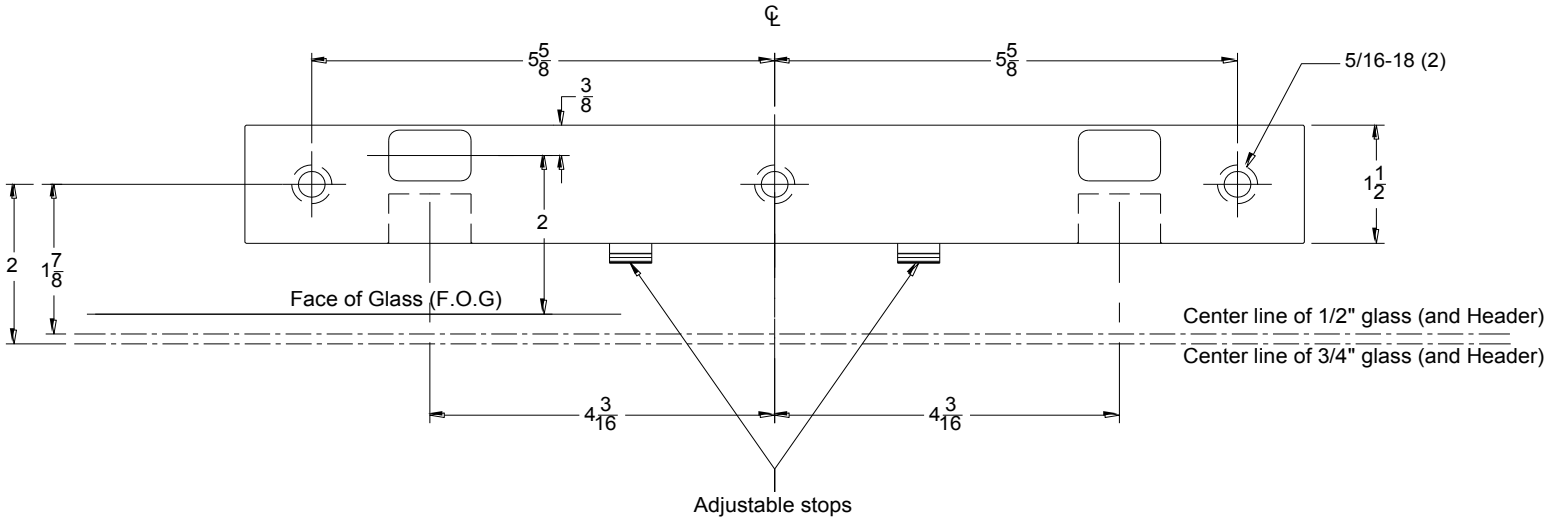

MPS1 / SINGLE DOOR

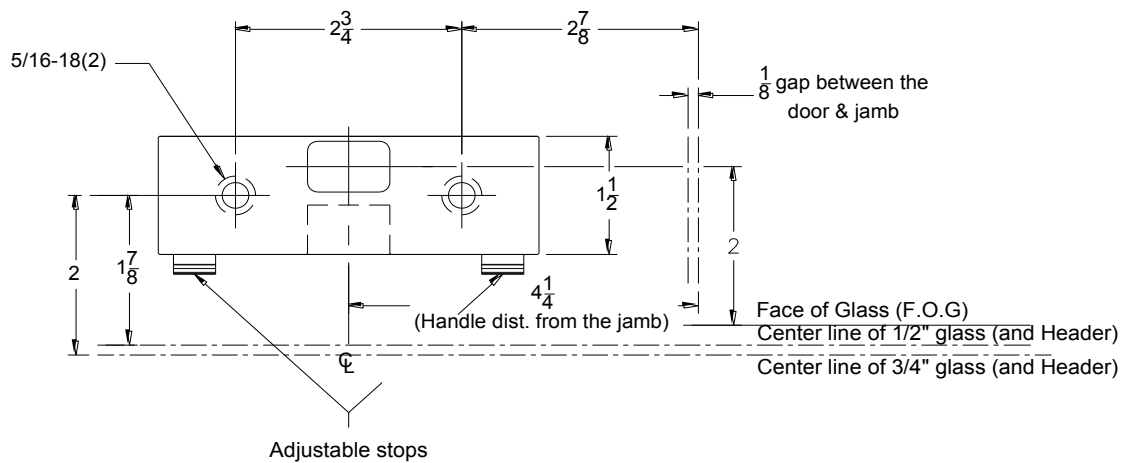

INSTALLATION & ADJUSTMENT OF DOOR STOP/STRIKE DOOR STOP WITH MANUAL STRIKE

To install:

Use socket head cap screws provided & install the strike in the header.

Apply the thread locker/Loctite to bolt threads before tightening with allen wrench.

After the door is installed, close the door & allow it to come to rest on the rubber stop pad the retractable bolt should automatically move upward engaging the strike (see illustration) the space between the face of the glass to the center of the handle (F.O.G.) should be 2"

If the retractable bolt is not engaging with the strike, then the door stops need to be adjusted. To correct this problem , move the door stops in.

if the door is rattling the retractable bolt is lose inside the strike.

To correct this problem, the door stops need to be moved out.

Adjustment :

To adjust the door stop simply remove the rubber end piece & you will see an opening for a 1/4" allen wrench. Insert the wrench & rotate in or out as needed

One complete turn will be equal to 1/16" adjustment .



Important information

Apply thread locker / Loctite
 to all fasteners

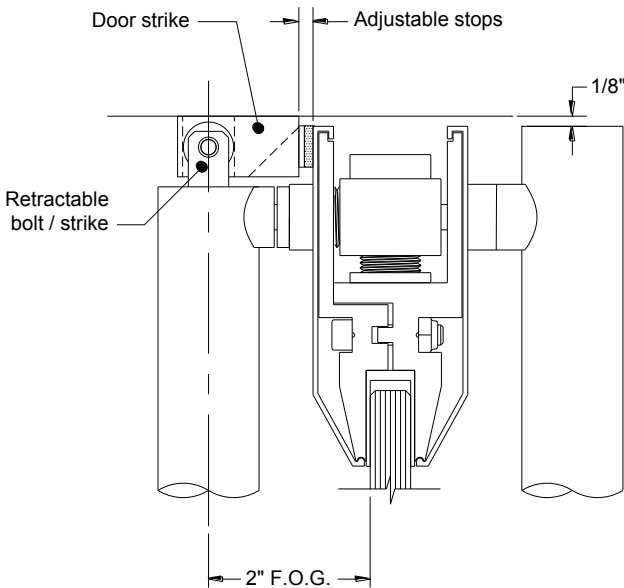

DOOR RAIL MOUNT

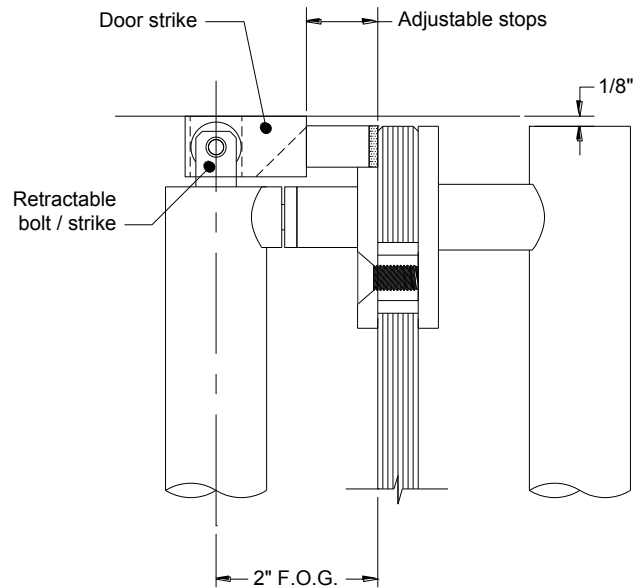

DIRECT TO GLASS MOUNTING

BOLT ADJUSTMENT FOR PROPER ENGAGING WITH THE STRIKE

If necessary, the retractable bolt can be adjusted. The centerline of the roller at the top of the retractable bolt should enter the strike a minimum of 1/8". The maximum upward adjustment is 3/4" when measuring from the top of the handle tubing to the top of the bolt.

To adjust the retractable bolt

"A" remove the flat head screw at the top of the panic handle but **do not remove the slotted head screw**

"B" rotate the retractable bolt 360 degrees in either direction to obtain the desired height adjustment. Rotate bolt to align interior threaded hole with countersunk hole in tubing.

"C" Replace flat head screw.

Note: if flat head screw is not securely replaced, the retractable bolt will randomly rotate, which will cause the bolt to improperly engage the strike.

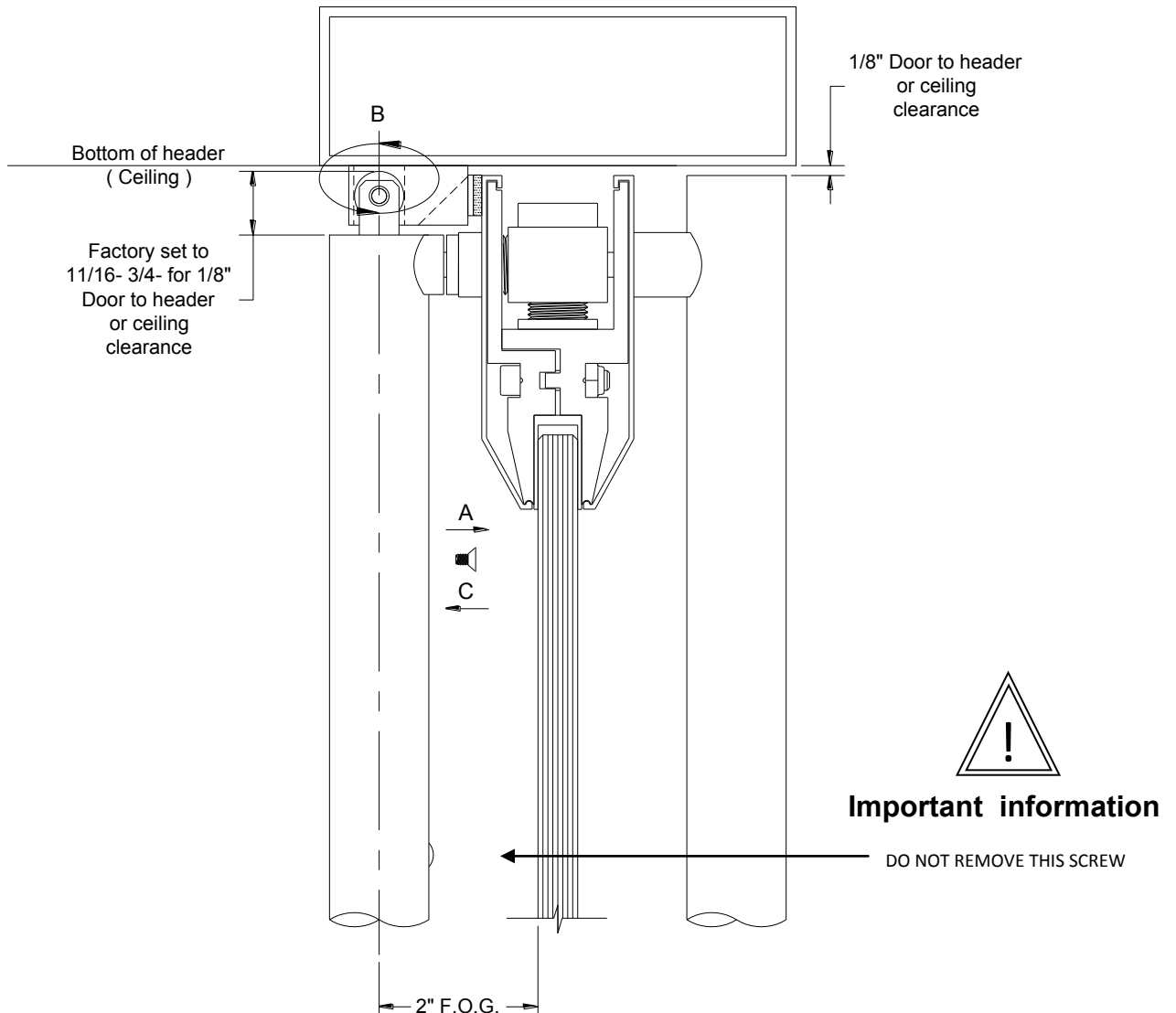

DOOR RAIL MOUNT

HEADER PREP FOR DOUBLE DOOR & SINGLE ADJUSTABLE DOOR STOPS WITH ELECTRIC STRIKE

DOUBLE DOOR

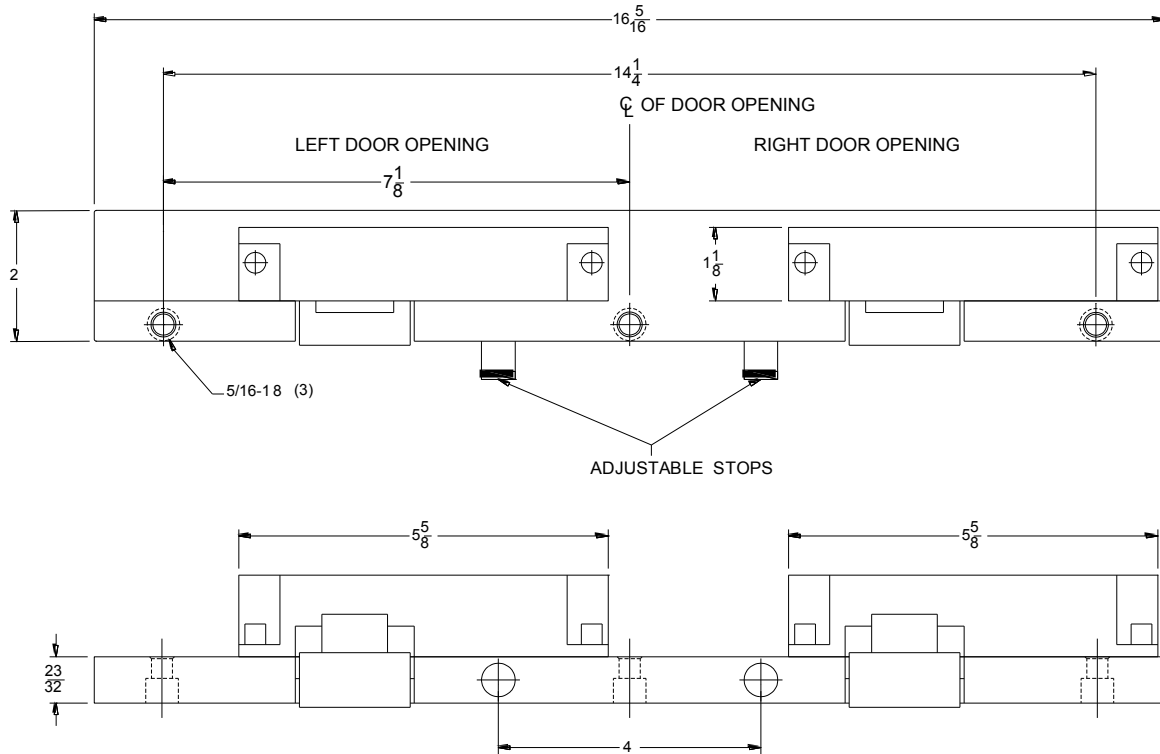

SINGLE DOOR

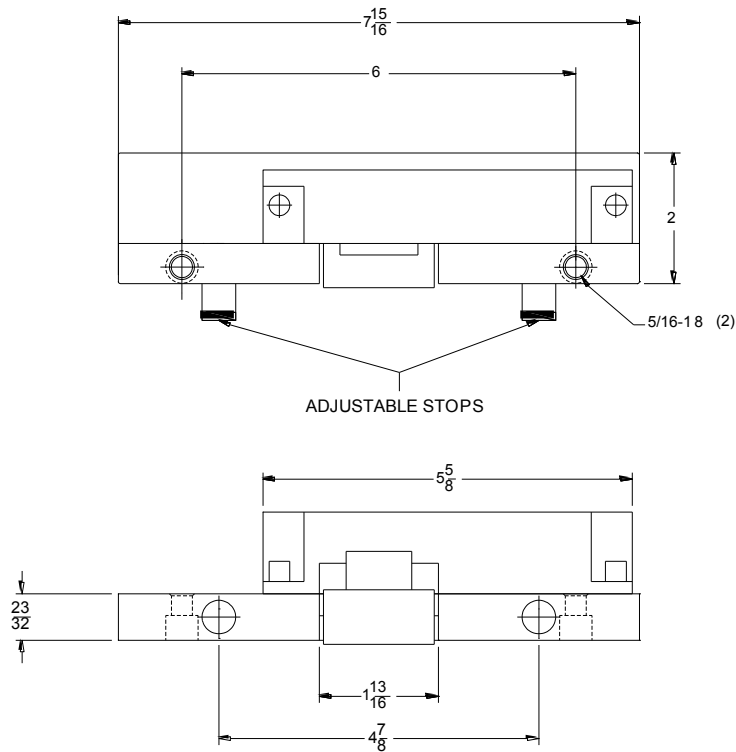

INSTALLATION & ADJUSTMENT OF DOOR STOP—STRIKE

DOOR STOP WITH ELECTRIC STRIKE

INSTALLATION

Remove cover retaining screw & door stop cover.

Install door stop—strike onto header using provided socket head cap screws (*Door stop mounting bolts shown on illustration*). Apply thread locker / Loctite to bolt threads prior to tightening with allen wrench. Replace door stop cover & fasten with cover retaining screw.



Important information

Apply thread locker / Loctite
 to all fasteners

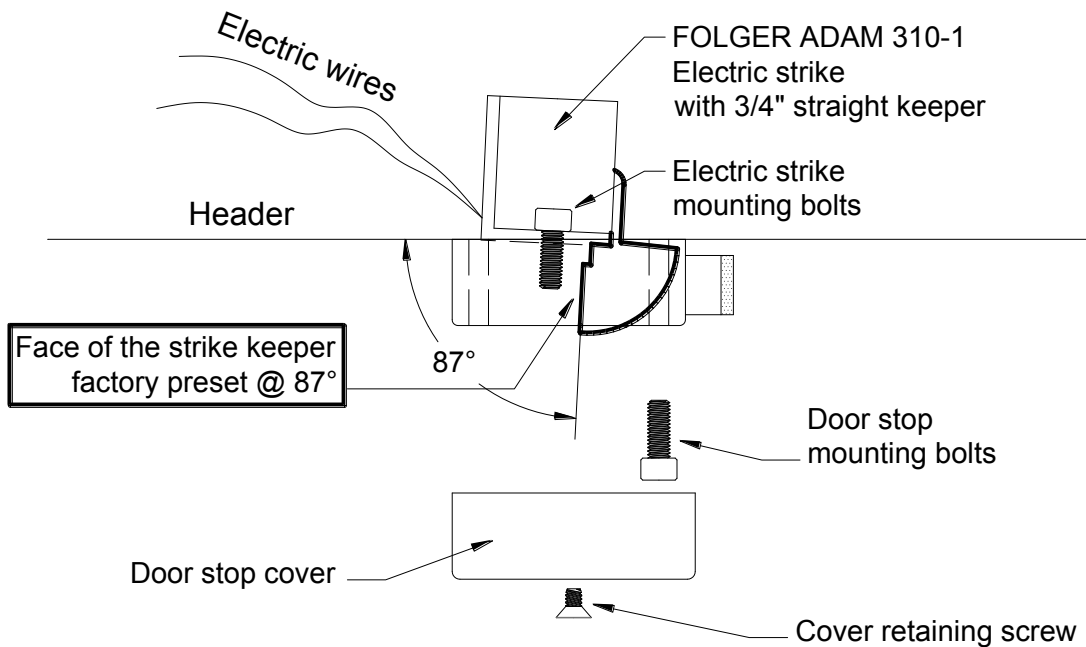

IMPORTANT NOTE FOR ELECTRIC STRIKE REPLACEMENT

Face of the strike keeper must be set @ 87degrees as illustrated

To replace strike

- o Turn off power to electric strike
- o Remove cover retaining screws & door stop cover
- o Remove door stop mounting bolts & gently lower door stop-latch keeper

Disconnect electrical wiring

- o Remove electric strike mounting bolts & install new strike
- o Reconnect wires to new electric strike using appropriate wire connectors
- o Apply thread locker / Loctite & tighten electric mounting bolts
- o Mount door stop / latch keeper in header & replace door stop cover
- o Turn on power to electric strike
- o Verify that the strike operates properly

ADJUSTMENT OF DOOR STOP/STRIKE DOOR STOP WITH ELECTRICAL STRIKE

After door has been installed & comes to rest on door stop rubber the retractable bolt should automatically move upward into the strike as illustrated. The distance from the face of glass (F.O.G.) to center of handle should be 2"

If retractable bolt is not fully engaging with the strike, the door stops need to be moved in

if the door is rattling or the retractable bolt is loose inside the strike door stops should be moved out.

Adjustment :

To adjust the door stop simply remove the rubber end piece & you will see an opening for a 1/4" allen wrench. Insert the wrench & rotate in or out as needed

One complete turn will be equal to 1/16" of adjustment .

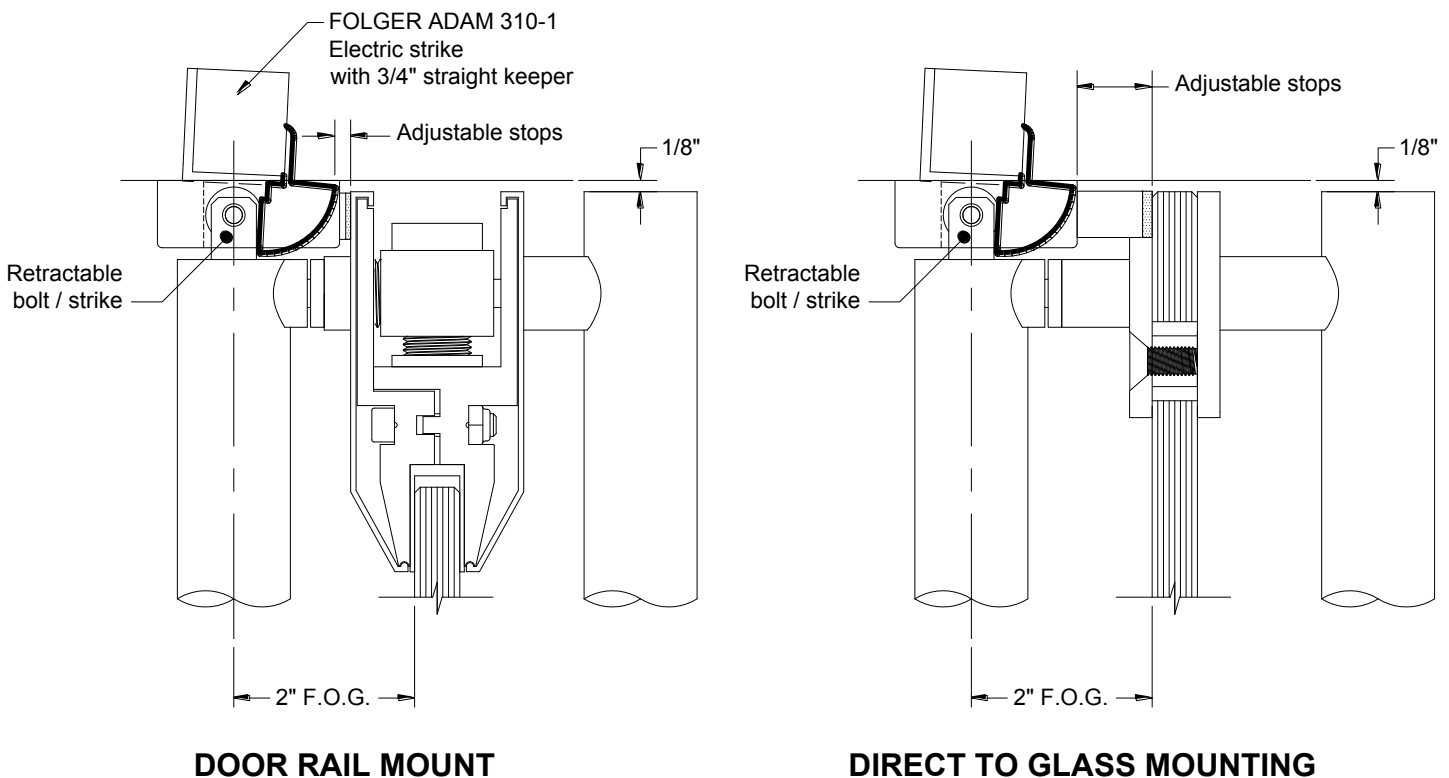

PRL PANIC HANDLE STANDARD REMOVABLE CORE

Removable core can be extracted using the control key provided with the panic handle or as an option the whole lock cylinder can be changed following the same steps explained on steps 1 thru 5 (see page 18 & 19)

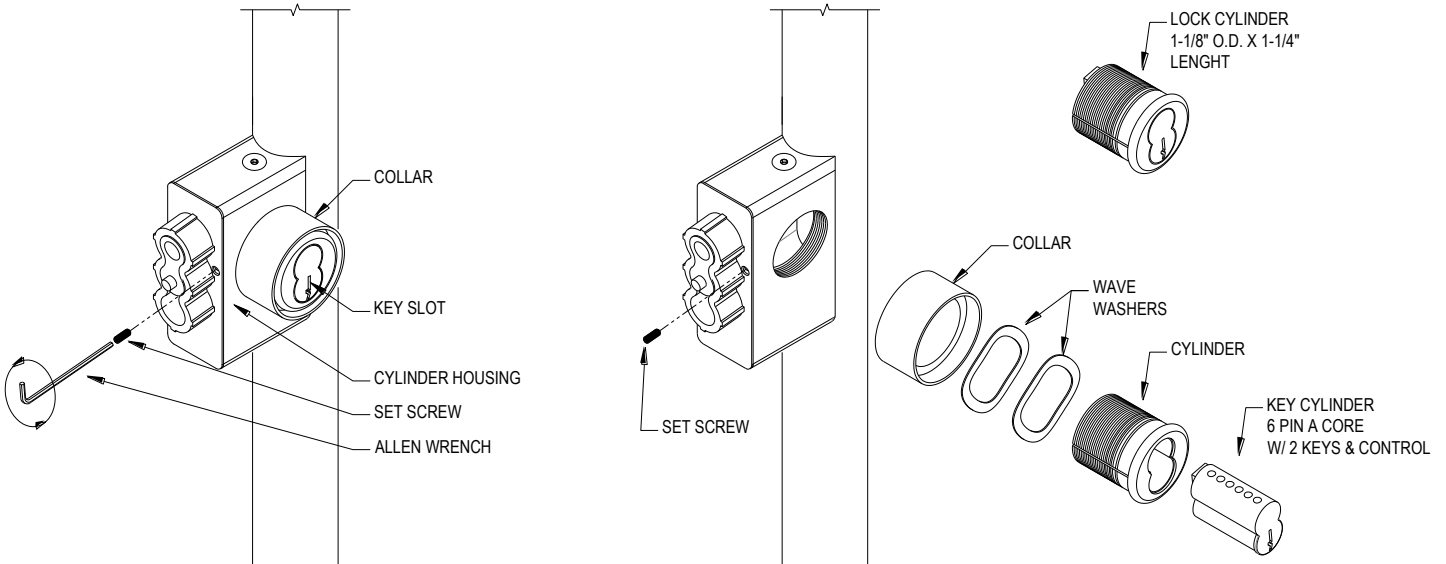

CYLINDER HOUSING

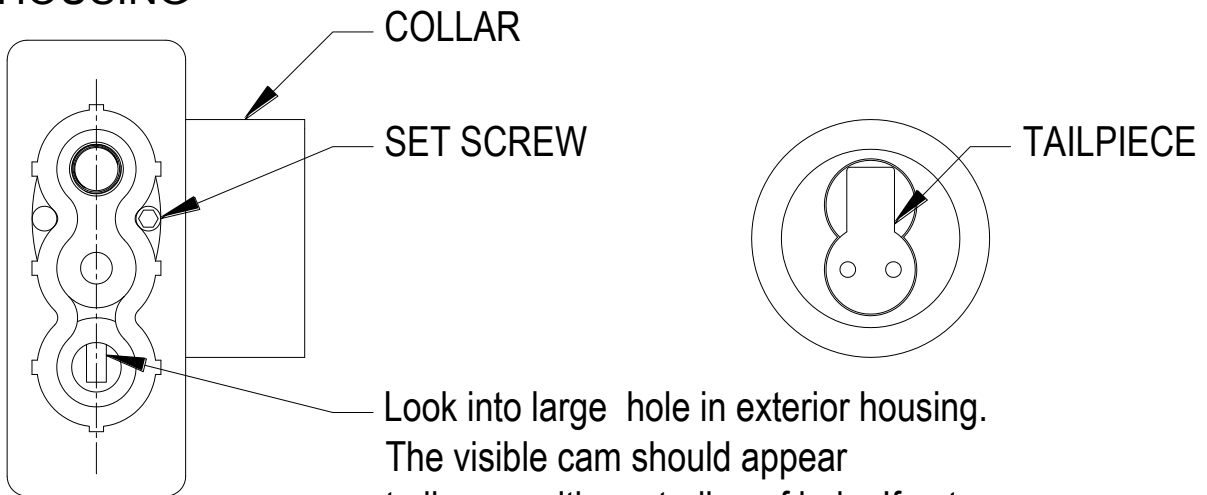

Look into large hole in exterior housing. The visible cam should appear to line up with centerline of hole. If not, turn cylinder in or out one turn so line up is accomplished. tighten set screw

Your **PRL** panic handle under normal operation conditions should not require any maintenance other than cleaning the bars. However, if you experience any difficulty with the operation of the system, do not attempt to repair the system yourself. It is highly recommended to contact the original installer or contact **PRL GLASS @ 800-433-7044**

Repair & replacement

Replacing the optional cylinder:

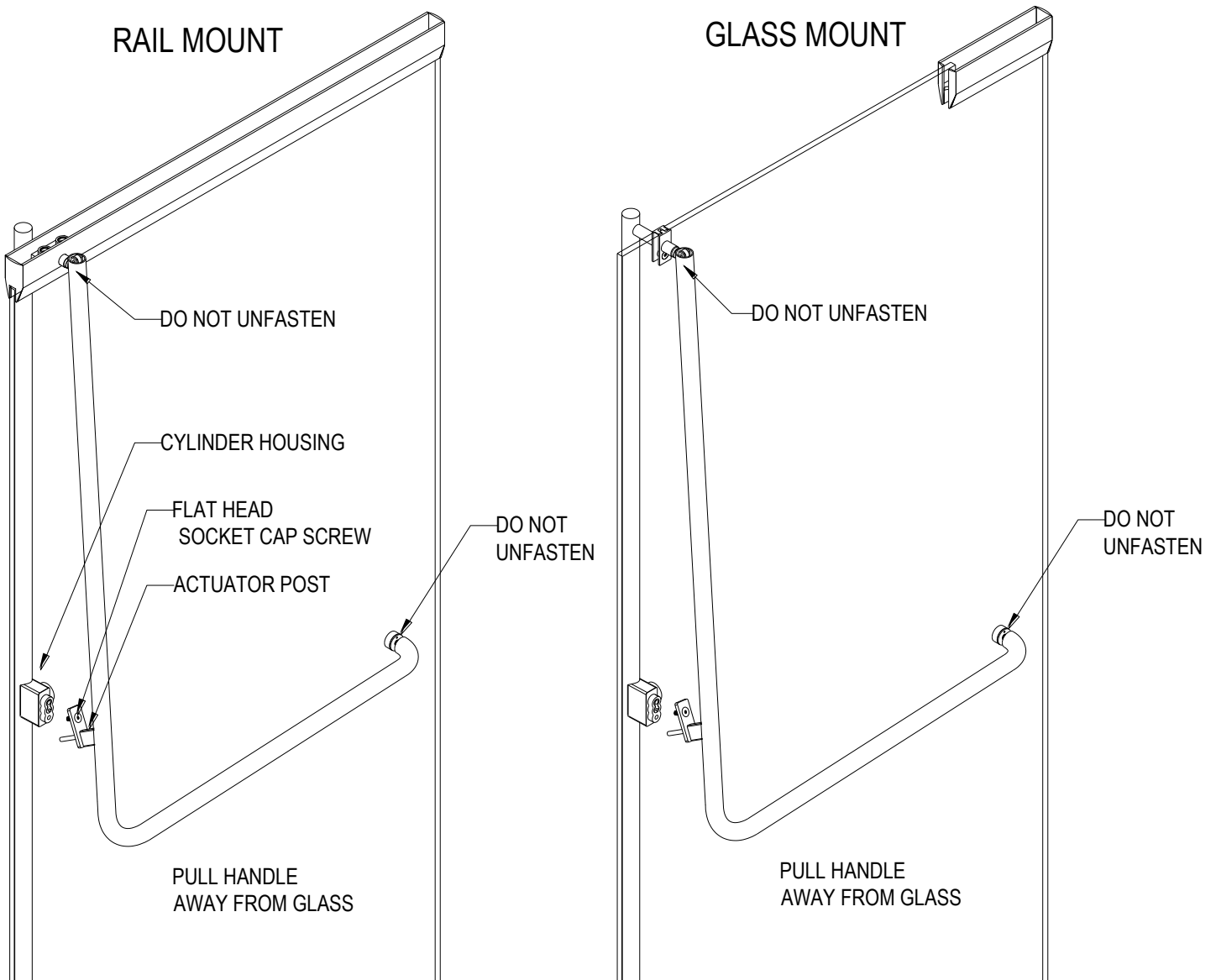

1.- Remove flat head socket cap screw

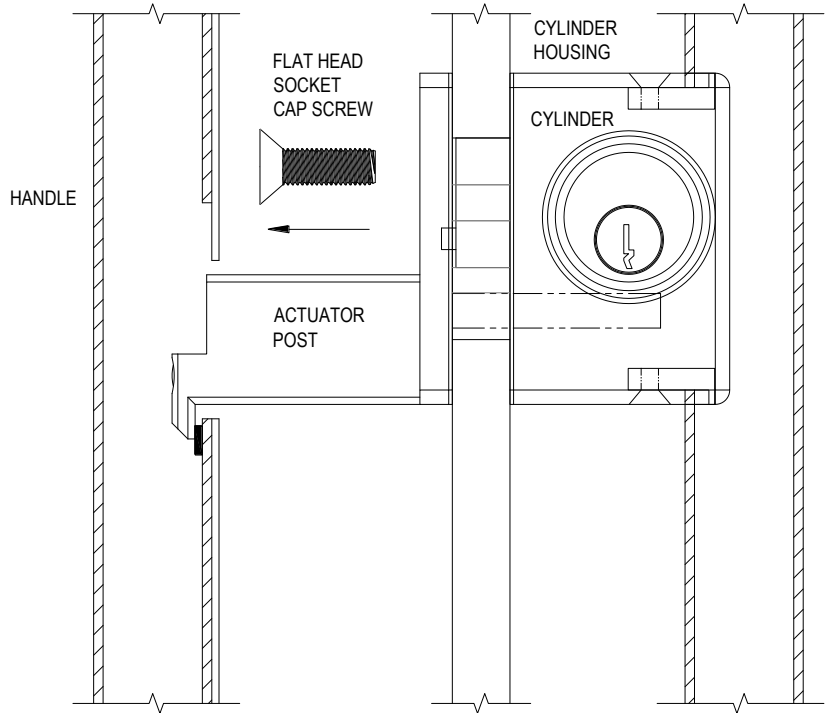

2.- Gently remove the handle away from the glass & remove the actuator post from the handle

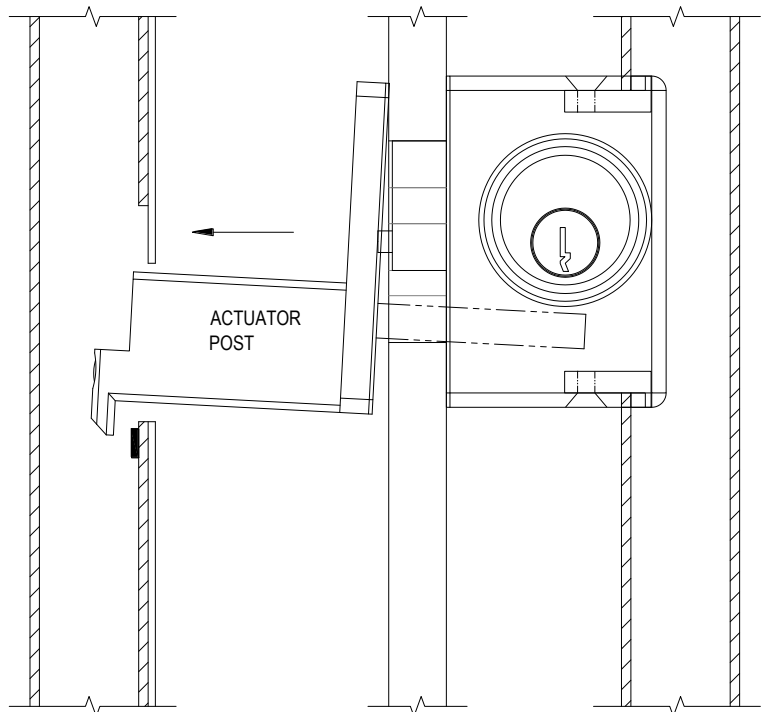

PRL PANIC HANDLE OPTIONAL CYLINDER

3.- Loosen the set screw holding the cylinder in place.

Use an allen wrench for this procedure

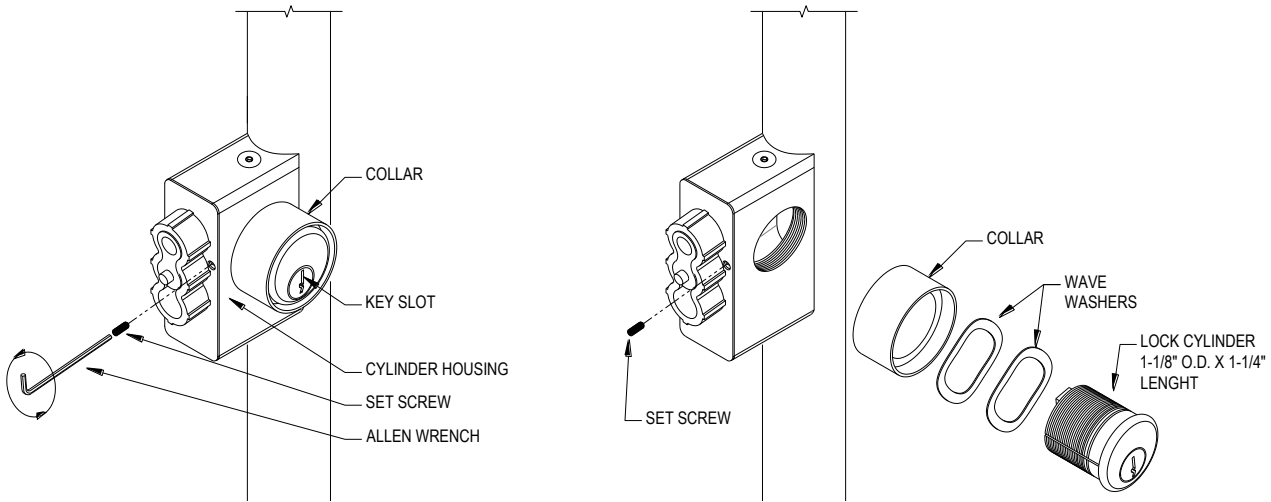

4.- Remove old cylinder & check to see if tailpiece matches new cylinder tailpiece. Also the length of the new cylinder must be the same as the old one. A cylinder of any other length will require a new length collar. Fasten in new cylinder until it stops inside the collar ring. Key slot should be on bottom of cylinder nearest the floor.

5.- to reassemble the unit, insert handle actuator post into panic handle & place it against the door

& attach to handle actuator post with the flat head socket cap screw.

CYLINDER HOUSING

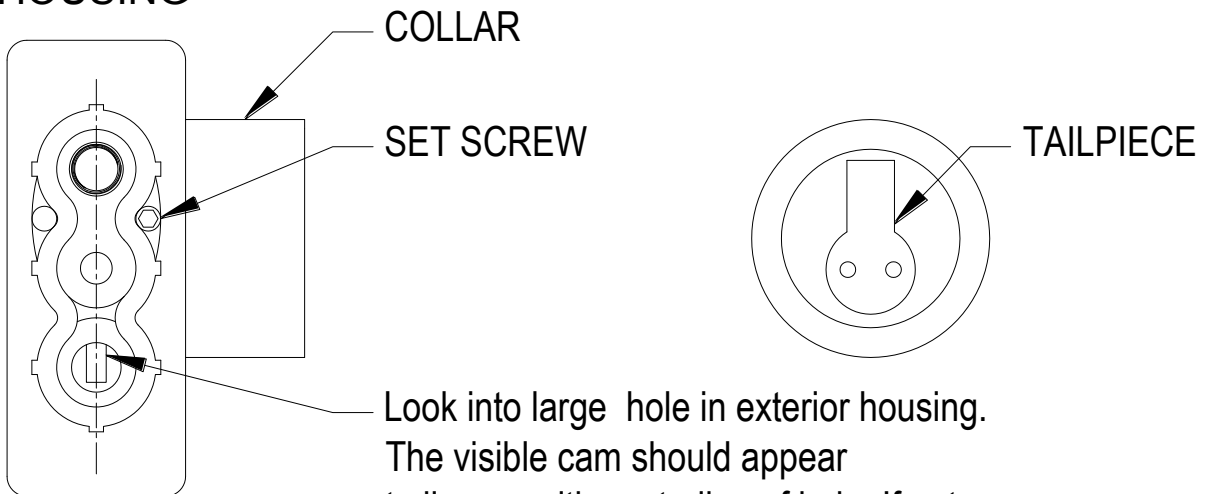

Look into large hole in exterior housing. The visible cam should appear to line up with centerline of hole. If not, turn cylinder in or out one turn so line up is accomplished. tighten set screw

MAINTENANCE OF STAINLESS STEEL FINISHES ON HANDLE

Polished #8 & brushed # 4 finishes on stainless steel (alloy 304) are one of the most durable & easiest finishes to maintain.

PRL GLASS recommends a soft clean cloth & a foam type spray glass cleaner on the soft cloth & rub the stainless steel part directionally parallel to its length. This method applies to both polished & brushed finishes.

Note: Do not use circular motions when cleaning stainless steel, especially on polished finishes, as doing so leaves fine polish lines on the surface. Do not use steel wool to clean brushed stainless steel. Steel wool leaves small pieces of wool in the brushed grooves. These pieces of wool will rust, thus the impression that the stainless steel is rusting, which is impossible.

MAINTENANCE OF BRASS BRONZE FINISHES ON HANDLE

Polished & brushed finishes applied to brass & bronze alloys must be routinely maintained to retain the desired appearance. The darkening or black spotting on the brass & bronze surfaces is simply oxidation taking place. If left untreated brass & bronze alloys will eventually turn entirely, but unevenly dark.

This dark oxidized state is the natural color of all copper alloys, which brass & bronze are included.

Maintenance of brass/bronze must be done on a routinely timely basis as needed. Depending on use & abuse, location, weather conditions or exposure to marine air, will determine the frequency that the finish will need attention.

Polished finishes (brass/bronze): polished brass is a simple process if done routinely.

PRL GLASS recommends “brasso metal polish” or equal which is applied much the same as car wax. Brass & bronze are directionally polished @ the factory parallel to the length of the part. Apply the brass polish with a soft clean cloth parallel to the length of the part with medium pressure. Allow the polish to dry & buff with a soft clean cloth. Repeat if necessary.

Note: when polishing brass or bronze do not use a circular motion as it will leave a circular pattern in the finish. PRL GLASS also suggests after re-polishing the brass or bronze, that a coat of “Harley’s pure carnuba wax” be applied to help maintain the finish.

Brushed/Satin finishes (brass/bronze): Maintenance of brushed or satin brass/bronze finishes is done using an entirely different method than that of a polished finished. PRL GLASS recommends a “Scotch brite” pad over the brass or bronze in the same direction as the existing finish (parallel to the length) will remove the oxidation from the surface. Medium pressure in long easy strokes should be all that is necessary.

Note: do not use brass polish to clean brushed/satin finishes. The polish will load up the groves in the brushed / satin finish making a simple clean job a lengthy one.

MAINTENANCE OF US10B STATUARY BRONZE ON HANDLE

The US10B is a process to age the brass/bronze surface to simulate the nature aging process.

The US10B will be specified in either oil rubbed or clear baked enamel to preserve the finish.

1.– Oil rubbed: after the aging process is complete, a hand applied lemon oil is rubbed onto the surface. The oil rubbed process allows the brass to continue to darken. On a frequent basis lemon oil should be re-applied with a soft clean cloth in the field. The frequency will determined when the metal surface appears dull & dry.

2.– Clear baked enamel: after the aging process is complete a clear baked enamel is applied to the brass surface to delay further darkening (aging). Clear baked enamel should be cleaned with a soft cotton cloth & a spray type glass cleaner. Do not soak the brass finish.

Note: the clear baked enamel finish will delay aging but not eliminate the possibility. The baked enamel finish is susceptible to abrasion & scratching. ***Clear baked enamel carries no warranty*** & it will eventually have to be re-done.

PRL GLASS recommends that a professional brass maintenance company be hired to do any of the field restorations.

We do not recommend any protective lacquering of brass & bronze door hardware. Lacquer wears off in certain use areas leaving a non-uniform or spotty finish.

The areas most affected are those where the handles contact the metal. Furthermore, rings worn on the fingers can cause the lacquer to be removed thus exposing the scratches of the lacquer.

However, protective lacquer will delay aging but not eliminate & will eventually have to be re-done.

If proper maintenance is followed, you will be able to elongate the time between re-finishing.

We recommend that a professional brass maintenance company be hired to do any of the field restorations.